

超高純度流体用ステンレス配管継手

KUZE CLEAN FITTINGS

KCF®

自動突合せ溶接



STAINLESS STEEL FITTINGS
FOR ULTRA-HIGH PURITY FLUIDS
AUTOMATIC BUTT WELDING

DIMENSIONS

PIPE SIZE(A-SIZE)	2
TUBE SIZE(INCH-SIZE)	3

PIPE SIZE(A-SIZE)

KCF STANDARD TYPE 1	4
KCF STANDARD TYPE 2	5
JOINT-FITTINGS	6
FLANGES	7
HEADERS	8

TUBE SIZE(INCH-SIZE)

KCF STANDARD TYPE 1	9
KCF STANDARD TYPE 2	10
JOINT-FITTINGS	11
FLANGES	12
HEADERS	13

DOUBLE-FIT	14 - 18
------------------	---------

MANUAL-WELDING FITTINGS

.....	19 - 20
-------	---------

PIPE SIZE (A-SIZE)

共通寸法表 : Dimensions

単位 (Unit) = mm

呼び径 Nominal pipe size	管端部外径 Outside diameter at end	端部の肉厚 Wall thickness at end		直管部長さ Straight end length	シニング長さ Thinning length	
		スケジュール Sch.				
OD	OD (OD ₁ , OD ₂)	T (T ₁ , T ₂)		r (r ₁ , r ₂)	J	
		5S	10S		5S	10S
8A	13.8	1.2	1.65	29	4	5
10A	17.3	1.2	1.65	36	4	5
15A	21.7	1.65	2.1	36	5	6
20A	27.2	1.65	2.1	36	5	6
25A	34.0	1.65	2.8	36	5	7
32A	42.7	1.65	2.8	46	5	7
40A	48.6	1.65	2.8	46	5	7
50A	60.5	1.65	2.8	46	5	7
65A	76.3	2.1	3.0	51	6	8
80A	89.1	2.1	3.0	51	6	8
100A	114.3	2.1	3.0	51	6	8
125A	139.8	2.8	3.4	56	7	9
150A	165.2	2.8	3.4	56	7	9
200A	216.3	2.8	4.0	56	7	10
250A	267.4	3.4	4.0			
300A	318.5	4.0	4.5			

S20S, S40をご希望の場合はお問い合わせ下さい。 Please contact us when you need S20S or S40.

管端の形状

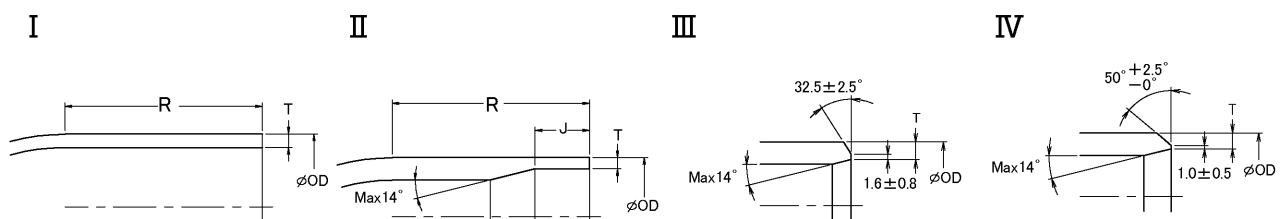

- 自動溶接の場合は、I または II が標準形状となります。
 - 手動溶接の場合は、III または IV のいずれかをご指定下さい。
- 注) ご使用にあたりシニング加工で支障がある場合はお申し出下さい。

- In the case of automatic welding, I or II is the standard form.
 - In the case of manual welding, select III or IV.
- N.B. Please contact us when you have problems with the thinning process.

TUBE SIZE (INCH-SIZE)

共通寸法表：Dimensions

単位 (Unit) = mm

呼び径 Nominal tube size	管端部外径 Outside diameter at end	端部の肉厚 Wall thickness at end	直管部長さ Straight end length	シニング長さ Thinning length
OD	OD (OD ₁ , OD ₂)	T (T ₁ , T ₂)	r (r ₁ , r ₂)	J
1/8"	3.18	0.7	29	
1/4"	6.35	1.0 (0.89)	29	4
3/8"	9.53	1.0 (0.89)	29	4
1/2"	12.7	1.0, 1.24 (1.65)	29	4
5/8"	15.88	1.0 (1.24)	36	4
3/4"	19.05	1.24, 1.65	36	4 (T=1.24), 5 (T=1.65)
1"	25.4	1.65, 1.24	36	5 (T=1.65), 4 (T=1.24)
1 1/4"	31.8	1.65	36	5
1 1/2"	38.1	1.65	46	5
2"	50.8	1.65	46	5
2 1/2"	63.5	1.65	51	5
3"	76.2	1.65	51	5
4"	101.6	2.11	51	6
5"	127.0	2.77, 3.05	56	8
6"	152.4	2.77, 3.05	56	8

寸法表以外の肉厚をご希望の場合はお問い合わせ下さい。 Please contact us when you need any thickness which is not listed above.

管端の形状

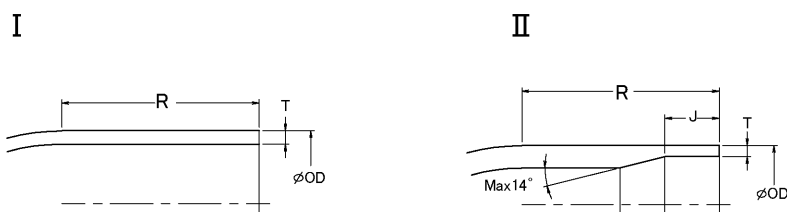

● I または II が標準形状となります。

● I or II is the standard form.

注) ご使用にあたりシニング加工で支障がある場合はお申し出下さい。

N.B. Please contact us when you have problems with the thinning process.

KCFスタンダードタイプ I

KCF STANDARD TYPE I

PIPE SIZE (A-SIZE)

製品寸法表 : Dimensions

単位 (Unit) = mm

呼び径 Nominal pipe size [RC, RE] (大径側) (Large end)	90°エルボ 90° Elbow		45°エルボ 45° Elbow		キャップ Cap	レジュューサー Reducer			
	ロング [90LR] Long radius	ショート [90SR] Short radius	ロング [45LR] Long radius		[CAP]	同心レジュューサー [RC] Concentric reducer	偏心レジュューサー [RE] Eccentric reducer		
OD (OD ₁)	R	A	R	A	R	B	E	小径側 呼び径 OD ₂ Nominal pipe size at small end	H
8A	* 25.4	55	* 12.7		25.4	40	12.7	[1/2", 3/8", 1/4"]	RC 80 RE 85
10A	* 25.4	62	* 12.7		25.4	47	19.1	[8A, 1/2", 3/8", 1/4"]	90
15A	38.1	75	* 12.7		38.1	52	25.4	[10A, 8A, 3/4", 1/2", 3/8", 1/4"]	100
20A	38.1	75	* 19.1		38.1	52	25.4	15A, [10A, 8A, 1", 3/4", 1/2", 3/8", 1/4"]	105
25A	38.1	75	25.4		38.1	52	38.1	20A, 15A, [10A, 8A, 1 1/4", 1", 3/4", 1/2", 3/8", 1/4"]	120
32A	47.6	94	31.8		47.6	66	38.1	25A, 20A, 15A, [1 1/2", 1 1/4"] (10A~8A, 1"~1/4")	125
40A	57.2	104	38.1		57.2	70	38.1	32A, 25A, 20A, 15A, [1 1/2"] (10A~8A, 1 1/4"~1/4")	130
50A	76.2	123	50.8		76.2	78	38.1	40A, 32A, 25A, 20A, [2"] (15A~8A, 1 1/2"~1/4")	140
65A	95.3	147	63.5		95.3	91	38.1	50A, 40A, 32A, 25A, [3", 2 1/2"] (20A~8A, 2"~1/4")	165
80A	114.3	166	76.2		114.3	99	50.8	65A, 50A, 40A, 32A, [3"] (25A~8A, 2 1/2"~1/4")	170
100A	152.4	204	101.6		152.4	115	63.5	80A, 65A, 50A, 40A, [4"] (32A~8A, 3"~1/4")	180
125A	190.5	250	127.0		190.5	145	76.2	100A, 80A, 65A, 50A, [5"] (40A~8A, 4"~1/4")	250
150A	228.6	290	152.4		228.6	155	88.9	125A, 100A, 80A, 65A, [6"] (50A~8A, 5"~1/4")	260
200A	304.8	375	203.2		304.8	195	101.6	150A, 125A, 100A (80A~8A, 6"~1/4")	280

形状

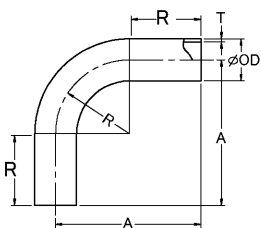

90° ロング/ショートエルボ [90LR] [90SR]

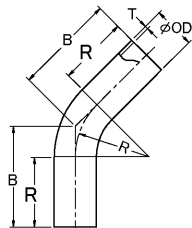

45° ロングエルボ [45LR]

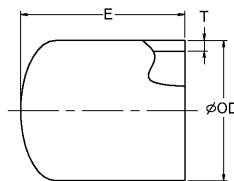

キャップ [CAP]

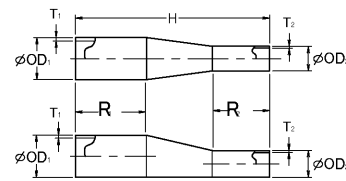

同心/偏心レジュューサー [RC] [RE]

- 外径 (OD)、肉厚 (T)、直管部長さ (R) はページ2及び3を参照。
- 90°、45° エルボの曲げRはJIS B2312の曲げRを採用しております。(表中 * 印以外)
- キャップは JIS B2312の規格品です。(但しプレーンエンド)
- 上記サイズ表のレジュューサーの小径側で []内の偏心タイプ及び ()内の同心・偏心タイプについてはお問い合わせ下さい。

- Please refer to pages 2 and 3 for outside diameter (OD), thickness (T) and length (R) of straight end length.
- JIS B2312 bend radius is applied to 90° and 45° elbow bend radius. (applicable to other than those marked *)
- Caps conform to JIS B2312 specifications (only plane end).
- Please contact us for reducers with smaller diameter side listed in [] brackets for eccentric type and listed in () brackets for both concentric and eccentric types.

KCFスタンダードタイプⅡ

KCF STANDARD TYPE 2

PIPE SIZE (A-SIZE)

製品寸法表 : Dimensions

単位(Unit)=mm

母管、大径側 呼び径 Nominal sizes of pipe and large end	同径ティーズ Equal tee		枝管、小径側 呼び径 Nominal sizes of branch pipe and small end	異径ティーズ Reducing tee [R-TEE]		キャップレジュサー Cap reducer [CAP-RC]	
	標準 Standard [E-TEE]	ショート Short [E-TEE-S]		C	M	E	Q
OD(OD ₁)	C=M		OD ₂	C	M	E	Q
8A	42	—	1/2", 3/8", 1/4"	42	42		
10A	49	—	8A, 1/2", 3/8", 1/4"	47	44		
15A	59	52	8A, 1/2", 3/8", 1/4"	47	44	25.4	60 (67)
			10A, 3/4", 5/8"	52	52		
20A	65	55	8A, 1/2", 3/8", 1/4"	47	47	25.4	60 67
			15A, 10A, 1", 3/4", 5/8"	55	55		
25A	68	59	8A, 1/2", 3/8", 1/4"	47	50	38.1	73 (80)
			20A, 15A, 10A, 1 1/4", 1", 3/4", 5/8"	59	59		
32A	88	74	8A, 1/2", 3/8", 1/4"	57	54	38.1	73 80
			25A, 20A, 15A, 10A, 1 1/4", 1", 3/4", 5/8"	68	62		
40A	95	77	8A, 1/2", 3/8", 1/4"	57	57	38.1	73 80 (90)
			25A, 20A, 15A, 10A, 1 1/4", 1", 3/4", 5/8"	68	65		
			32A, 1 1/2"	77	77		
50A	102	83	8A, 1/2", 3/8", 1/4"	57	63	38.1	73 80 (90)
			25A, 20A, 15A, 10A, 1 1/4", 1", 3/4", 5/8"	68	71		
			40A, 32A, 2", 1 1/2"	83	83		
65A	121	97	8A, 1/2", 3/8", 1/4"	61	71	38.1	73 80 (90) (100)
			25A, 20A, 15A, 10A, 1 1/4", 1", 3/4", 5/8"	72	79		
			50A, 40A, 32A, 2", 1 1/2"	88	90		
			2 1/2"	97	97		
80A	130	103	8A, 1/2", 3/8", 1/4"	61	77	50.8	85 92 102 (110)
			25A, 20A, 15A, 10A, 1 1/4", 1", 3/4", 5/8"	72	85		
			50A, 40A, 32A, 2", 1 1/2"	88	96		
			65A, 3", 2 1/2"	103	103		
100A	145	116	8A, 1/2", 3/8", 1/4"	61	90	63.5	98 105 115 (125)
			25A, 20A, 15A, 10A, 1 1/4", 1", 3/4", 5/8"	72	98		
			50A, 40A, 32A, 2", 1 1/2"	88	109		
			80A, 65A, 4", 3", 2 1/2"	116	116		
125A	160	—	8A, 1/2", 3/8", 1/4"	80	110	76.2	120 130 140 (150) (160)
			25A, 20A, 15A, 10A, 1 1/4", 1", 3/4", 5/8"	100	120		
			50A, 40A, 32A, 2", 1 1/2"	120	130		
			100A, 80A, 65A, 4", 3", 2 1/2"	140	140		
			5"	160	160		
150A	170	—	8A, 1/2", 3/8", 1/4"	90	130	88.9	130 140 150 160 (170)
			25A, 20A, 15A, 10A, 1 1/4", 1", 3/4", 5/8"	110	140		
			50A, 40A, 32A, 2", 1 1/2"	130	150		
			100A, 80A, 65A, 4", 3", 2 1/2"	150	160		
			125A, 5"	170	170		
200A	190	—	8A, 1/2", 3/8", 1/4"	100	150	101.6	140 150 160 170 (180)
			25A, 20A, 15A, 10A, 1 1/4", 1", 3/4", 5/8"	120	160		
			50A, 40A, 32A, 2", 1 1/2"	140	170		
			100A, 80A, 65A, 4", 3", 2 1/2"	160	180		
			150A, 125A, 6", 5"	180	190		

形状

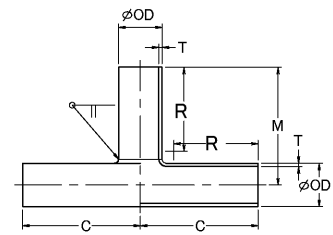

同径ティーズ [E-TEE] [E-TEE-S]

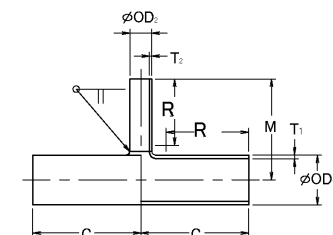

異径ティーズ [R-TEE]

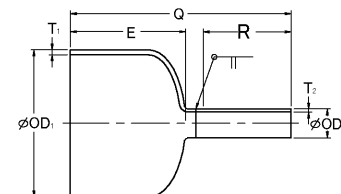

キャップレジュサー [CAP-RC]



- 外径 (OD)、肉厚 (T)、直管部長さ (R) はページ2及び3を参照。
- 枝部及び小径部は“玉抜き製法+短管突合せTIG溶接”とします。(TEE) (CAP-RC)
- C、M及びQ寸法で掲記以外の寸法をご要望の場合はご相談下さい。
- Please refer to pages 2 and 3 for outside diameter (OD), thickness (T) and length (R) of straight end length.
- “Extrusion process + short pipe-matching TIG welding” technique is applied to branch part and smaller diameter side. (TEE) (CAP-RC)
- Please consult us when you need C, M&Q measurements other than those shown here.

ジョイント継手 JOINT-FITTINGS

PIPE SIZE (A-SIZE)

製品寸法表 : Dimensions

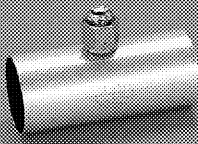
単位 (Unit) = mm

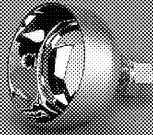
呼び径 Nominal pipe size	J-ティーズ [J-TEE] Joint tee			J-レジュースー [J-RC] Joint reducer		J-キャップ [J-CAP] Joint cap		
								
	ジョイント部 Joint 1/4", 3/8", 1/2"			ジョイント部 Joint 1/4", 3/8", 1/2"		ジョイント部 Joint 1/4", 3/8", 1/2"		
		メス [F] Female	オス [M] Male	メス [F] Female	オス [M] Male	キャップ長さ Cap length	メス [F] Female	オス [M] Male
OD	C	M	M	H	H	E	Q	Q
8A	45	35	45	90	100			
10A	52	37	47	100	110	19.1	48	58
15A	52	39.5	49.5	110	120	25.4	55	65
20A	55	42.5	52.5	115	125	25.4	55	65
25A	59	46.5	56.5	130	140	38.1	68	78
32A	68	51	61			38.1	68	78
40A	68	54	64			38.1	68	78
50A	68	60	70			38.1	68	78
65A	72	68	78			38.1	68	78
80A	72	74.5	84.5			50.8	81	91
100A	72	87	97			63.5	94	104
125A	100	100	110			76.2	107	117
150A	110	113	123			88.9	120	130
200A	120	138.5	148.5			101.6	133	143

形状

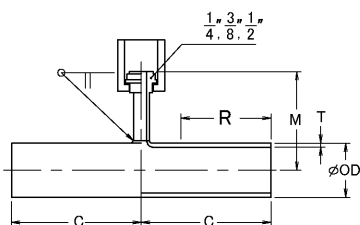

J-ティーズ [J-TEE]

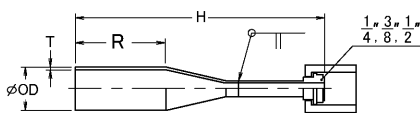

J-レジュースー [J-RC]

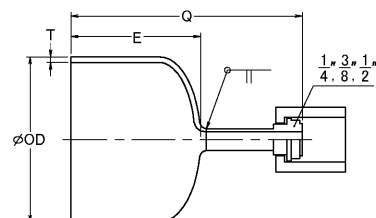

J-キャップ [J-CAP]

- 外径 (OD)、肉厚 (T)、直管部長さ (R) はページ2を参照。
- ジョイント部は“玉抜き製法+ジョイント突合せTIG溶接”とします。(JT) (JC)
- ジョイント部はVCR、UJR、MCG、JSKの1/4”、3/8”、1/2”とします。メス (F)、オス (M) も合わせてご指示下さい。
- M寸法及びQ寸法は掲記基準寸法と異なる場合がありますので製作図面等でご確認下さい。



- Please refer to page 2 for outside diameter (OD), thickness (T) and length (R) of straight end length.
- “Extrusion process+joint-matching TIG welding” technique is applied to joint part. (JT) (JC)
- Joint part is 1/4”, 3/8”, 1/2” of VCR, UJR, MCG and JSK. Please indicate which you need, male or female.
- There are some cases where M measurements and Q measurements are different from the standard measurements shown here. Please check your requisite measurement with

フランジ接続タイプ FLANGES

PIPE SIZE (A-SIZE)

製品寸法表 : Dimensions

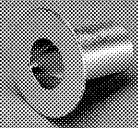
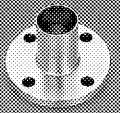
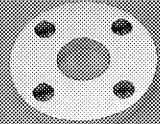
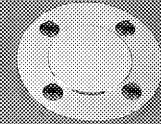
単位(Unit)=mm

呼び径 Nominal pipe size	クリーンラップ [CLLJ10K][CLLJ5K] Clean lap				パイプフランジ [P-FLANGE] Pipe flange	JISフランジ [FLANGE][BLIND] JIS Flange, Blind								テフロン パッキン [TEFLON-P] Teflon packing 厚さ Thickness t=2		
																
	長さ Length	つば径G Diameter of lap		コーナーR Corner	長さ Length	JIS10K				JIS5K				JIS10K		JIS5K
外 径 Outside dia.		厚 さ Thick- ness	ボルト数 No. of bolts	ボルト径 Dia. of bolt		外 径 Outside dia.	厚 さ Thick- ness	ボルト数 No. of bolts	ボルト径 Dia. of bolt	外 径 Outside dia.	内 径 Inside dia.	外 径 Outside dia.				
OD	FF	JIS10K	JIS5K	R	FP	D	FT	N	M	D	FT	N	M	OD	ID	OD
10A	55	46	39	1.5~3	100	90	12	4	M12	75	9	4	M10	53	18	45
15A	55	51	44	1.5~3	100	95	12	4	M12	80	9	4	M10	58	22	50
20A	55	56	49	1.5~3	100	100	14	4	M12	85	10	4	M10	63	28	55
25A	55	67	59	1.5~3	100	125	14	4	M16	95	10	4	M10	74	35	65
32A	70	76	70	2~4	100	135	16	4	M16	115	12	4	M12	84	43	78
40A	70	81	75	2~4	100	140	16	4	M16	120	12	4	M12	89	49	83
50A	70	96	85	2~4	100	155	16	4	M16	130	14	4	M12	104	61	93
65A	75	116	110	2.5~5	100	175	18	4	M16	155	14	4	M12	124	77	118
80A	75	126	121	2.5~5	100	185	18	8	M16	180	14	4	M16	134	90	129
100A	75	151	141	2.5~5	100	210	18	8	M16	200	16	8	M16	159	115	149
125A	85	182	176	3~6	200	250	20	8	M20	235	16	8	M16	190	141	184
150A	90	212	206	3~6	200	280	22	8	M20	265	18	8	M16	220	167	214
200A	90	262	252	3~6	200	330	22	12	M20	320	20	8	M20	270	218	260

形状

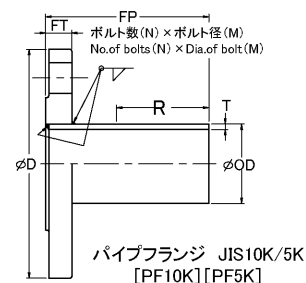
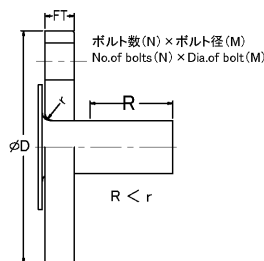
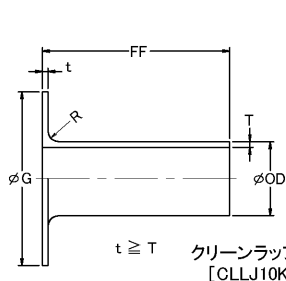

- 外径 (OD)、肉厚 (T)、直管部長さ (R) はページ2を参照。
- クリーンラップのルーズフランジの材質はSUS304を標準とします。
- パイプフランジ内面の隅肉溶接は研磨され、その表面粗さは要求仕様を確保します。(BA, EP)
- フランジは JIS B2220の規格品です。パイプフランジ及び研磨仕様のフランジはRFタイプとします。
- テフロンパッキンの寸法は“JIS B2202管フランジのガスケット座寸法”を準用します。
- JIS 20Kについてはお問い合わせ下さい。

- Please refer to page 2 for outside diameter (OD), thickness (T) and length (R) of straight end length.
- Standard material used for clean lap loose flanges is SUS304.
- The fillet welded interior of the pipe flange is polished, and its surface roughness can be finished according to your specifications. (BA, EP)
- Flanges conform to JIS B2220 specifications. Pipe flanges and polished flanges are RF type.
- “JIS B2202 flange gasket seat size” applies to our teflon packing measurement.
- Please contact us when you need information about JIS20K.

ヘッダー HEADERS

PIPE SIZE (A-SIZE)

製品寸法表 : Dimensions

単位 (Unit) = mm

母管 呼び径 Nominal pipe size	クリーンヘッダー [KCH] 枝管 OD (最小ピッチPは、J-KCHにも適用) Clean header Branch tube (Minimum pitch P applies to J-KCH)																母管 Mother pipe	J-ヘッダー [J-KCH] Joint-header			
	最小ピッチP Minimum Pitch 枝管高さM Branch tube height	1/4"	3/8"	1/2"	3/4"	1"	8A	10A	15A	20A	25A	32A	40A	50A	65A	80A		100A	最小管端長さ Length of minimum end EL	ジョイント部 Joint 1/4", 3/8", 1/2" 枝管高さ M Branch tube height	メス [F] Female
8A	P=	45	45	45			45											23	35	45	
	M=	42	42	42			42														
10A	P=	55	55	55			55	57										29	37	47	
	M=	44	44	44			44	49													
15A	P=	55	55	55	59		55	57	60									31	39.5	49.5	
	M=	44	44	44	52		44	52	52												
20A	P=	55	55	55	59	62	55	57	60	63								34	42.5	52.5	
	M=	47	47	47	55	55	47	55	55	55											
25A	P=	55	55	55	59	62	55	57	60	63	67							42	46.5	56.5	
	M=	50	50	50	59	59	50	59	59	59	59										
32A	P=	55	55	55	59	62	55	57	60	63	70	75						46	51	61	
	M=	54	54	54	62	62	54	62	62	62	62	74									
40A	P=	60	60	60	64	67	60	62	65	68	72	77	80					49	54	64	
	M=	57	57	57	65	65	57	65	65	65	65	77	77								
50A	P=	60	60	60	64	67	60	62	65	68	72	77	80	88				60	60	70	
	M=	63	63	63	71	71	63	71	71	71	71	83	83	83							
65A	P=	67	67	67	71	74	67	69	72	75	79	84	87	95	104			68	68	78	
	M=	71	71	71	79	79	71	79	79	79	79	90	90	90	97						
80A	P=	77	77	77	81	84	77	79	82	85	89	94	97	105	114	120		80	74.5	84.5	
	M=	77	77	77	85	85	77	85	85	85	85	96	96	96	103	103					
100A	P=	85	85	85	89	92	85	87	90	93	97	102	105	113	122	128	140	92	87	97	
	M=	90	90	90	98	98	90	98	98	98	98	109	109	109	116	116	116				

形状

最大長さ Max. length L=4,000mm

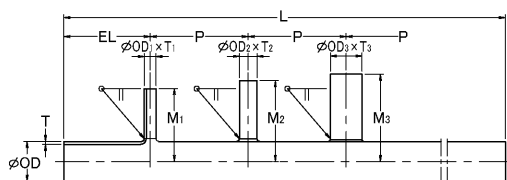

クリーンヘッダー [KCH]

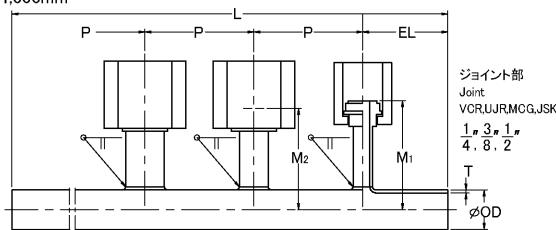
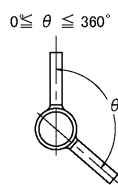

J-ヘッダー [J-KCH]

- 外径 (OD)、肉厚 (T)、直管部長さ (R) はページ2及び3を参照。
- 枝部は“玉抜き製法+枝管TIG溶接”とします。
- 長さ4,000L超、外径100A超をご要望の場合はお問い合わせ下さい。
- となり合う枝管が異なる径の場合の最小ピッチ(P)は大径側のピッチを基準とします。
- 2本の枝管がピッチ (P) を取る場合の角度 θ は任意に取ることができます。

- Please refer to pages 2 and 3 for outside diameter (OD), thickness (T) and length (R) of straight end length.
- “Extrusion process + branch tube-matching TIG welding” technique is applied to branch part.
- When you need length over 4,000L and outer diameter over 100A, please ask us whether it is available.
- Where neighboring branch tubes have different diameters, the minimum pitch between is determined on the basis of the pitch on the larger diameter side.
- When two branch tubes take a pitch (P), pitch angle θ can be determined at your option.

KCFスタンダードタイプ I

KCF STANDARD TYPE I

TUBE SIZE (INCH-SIZE)

製品寸法表 : Dimensions

単位 (Unit) = mm

呼び径 Nominal tube size [RC, RE] (大径側) (Large end)	90° エルボ(ロング) [90LR] 90° Elbow		45° エルボ(ロング) [45LR] 45° Elbow		キャップ [CAP] Cap	同心レジュューサー [RC] Concentric reducer	偏心レジュューサー [RE] Eccentric reducer
	OD (OD ₁)	R	A	R	B	E	小径側 呼び径 OD ₂ Nominal tube size at small end
1/4"	20	49	20	38	12.7	[1/8"]	70
3/8"	23	52	23	39	12.7	[1/4"]	RC70 RE80
1/2"	25	54	25	40	12.7	3/8", [1/4"]	RC75 RE85
5/8"	28	64	28	48	12.7	[1/2", 3/8", 1/4", 8A]	90
3/4"	30	66	30	49	19.1	[5/8", 1/2", [3/8", 1/4", 10A] (8A)	100
1"	33	69	33	50	25.4	3/4", [5/8", 1/2", [3/8", 1/4", 15A] (10A~8A)	105
1 1/4"	47.6	84	47.6	56	38.1	1", [3/4", 20A] (5/8"~1/4", 15A~8A)	120
1 1/2"	57.2	104	57.2	70	38.1	1 1/4", 1", [3/4", 25A] (5/8"~1/4", 20A~8A)	125
2"	76.2	123	76.2	78	38.1	1 1/2", [1 1/4"], 1", [40A] (3/4"~1/4", 32A~8A)	130
2 1/2"	95.3	147	95.3	91	38.1	2", 1 1/2", [1 1/4", 50A] (1"~1/4", 40A~8A)	140
3"	95.3	147	95.3	91	38.1	2 1/2", 2", [1 1/2", 50A] (1 1/4"~1/4", 40A~8A)	165
4"	133.4	185	133.4	107	63.5	3", 2 1/2", 2", [80A] (1 1/2"~1/4", 65A~8A)	175
5"	190.5	250	190.5	140		[100A] (4"~1/4", 80A~8A)	230
6"	228.6	290	228.6	155		[125A] (5"~1/4", 100A~8A)	250

形状

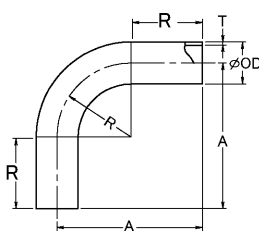

90° ロングエルボ[90LR]

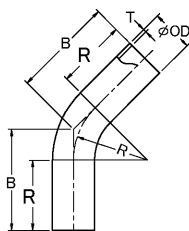

45° ロングエルボ[45LR]

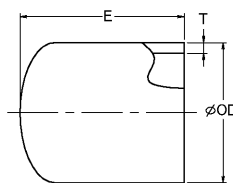

キャップ[CAP]

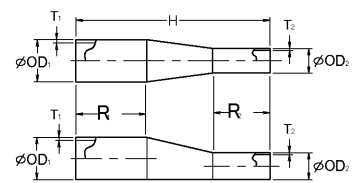

同心/偏心レジュューサー[RC][RE]

- 外径 (OD)、肉厚 (T)、直管部長さ (R) はページ2及び3を参照。
- 上記サイズ表のレジュューサーの小径側で [] 内の偏心タイプ及び () 内の同心・偏心タイプについてはお問い合わせ下さい。

- Please refer to pages 2 and 3 for outside diameter (OD), thickness (T) and length (R) of straight end length.
- Please contact us for reducers with smaller diameter side listed in [] brackets for eccentric type and listed in () brackets for both concentric and eccentric types.

KCFスタンダードタイプ II

KCF STANDARD TYPE 2

TUBE SIZE (INCH-SIZE)

製品寸法表 : Dimensions

単位 (Unit) = mm

母管、大径側 呼び径 Nominal sizes of tube and large end	同径ティーズ [E-TEE] Equal tee	枝管、小径側 呼び径 Nominal sizes of branch tube and small end	異径ティーズ [R-TEE] Reducing tee		キャップレジュサー [CAP-RC] Cap reducer	
			C	M	E	Q
OD(OD ₁)	C=M	OD ₂	C	M	E	Q
1/4"	35					
3/8"	37	1/4"	37	37		
1/2"	39	3/8", 1/4"	39	39		
5/8"	49	1/2", 3/8", 1/4", 8A	47	44		
3/4"	52	1/2", 3/8", 1/4", 8A	47	44	19.1	54
		5/8", 10A	52	52		60
1"	55	1/2", 3/8", 1/4", 8A	47	47	25.4	60
		3/4", 5/8", 15A, 10A	55	55		67
1 1/4"	59	1/2", 3/8", 1/4", 8A	47	50	38.1	73
		1", 3/4", 5/8", 20A, 15A, 10A	59	59		80
1 1/2"	74	1/2", 3/8", 1/4", 8A	57	54	38.1	73
		1 1/4", 1", 3/4", 5/8", 25A, 20A, 15A, 10A	68	62		80
2"	77	1/2", 3/8", 1/4", 8A	57	57	38.1	73
		1 1/4", 1", 3/4", 5/8", 25A, 20A, 15A, 10A	68	65		80
		1 1/2", 40A, 32A	77	77		(90)
2 1/2"	90	1/2", 3/8", 1/4", 8A	61	63	38.1	73
		1 1/4", 1", 3/4", 5/8", 25A, 20A, 15A, 10A	72	71		80
		2", 1 1/2", 50A, 40A, 32A	90	83		(90)
3"	97	1/2", 3/8", 1/4", 8A	61	71	38.1	73
		1 1/4", 1", 3/4", 5/8", 25A, 20A, 15A, 10A	72	79		80
		2", 1 1/2", 50A, 40A, 32A	90	90		(90)
		2 1/2", 65A	97	97		(95)
4"	110	1/2", 3/8", 1/4", 8A	61	87	63.5	98
		1 1/4", 1", 3/4", 5/8", 25A, 20A, 15A, 10A	72	95		105
		2", 1 1/2", 50A, 40A, 32A	90	105		115
		3", 2 1/2", 80A, 65A	110	110		(125)
5"	140	1/2", 3/8", 1/4", 8A	70	100		
		1 1/4", 1", 3/4", 5/8", 25A, 20A, 15A, 10A	90	110		
		2", 1 1/2", 50A, 40A, 32A	110	120		
		4", 3", 2 1/2", 100A, 80A, 65A	140	140		
6"	160	1/2", 3/8", 1/4", 8A	80	115		
		1 1/4", 1", 3/4", 5/8", 25A, 20A, 15A, 10A	100	125		
		2", 1 1/2", 50A, 40A, 32A	120	135		
		4", 3", 2 1/2", 100A, 80A, 65A	140	145		
		5", 125A	160	160		

形状

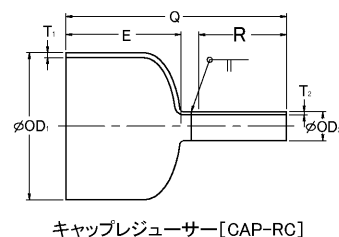
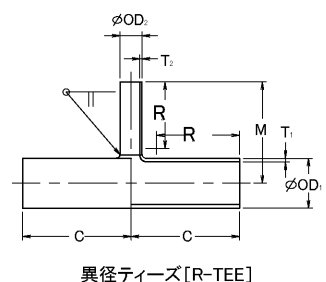
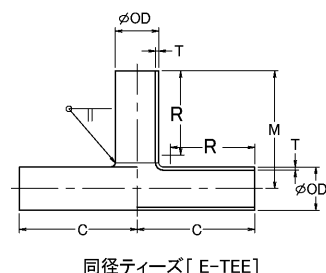

- 外径 (OD)、肉厚 (T)、直管部長さ (R) はページ2及び3を参照。
- 枝部及び小径部は“玉抜き製法+短管突合せTIG溶接”とします。(TEE) (CAP-RC)
- C、M及びQ寸法で掲記以外の寸法をご要望の場合はご相談下さい。
- Please refer to pages 2 and 3 for outside diameter (OD), thickness (T) and length (R) of straight end length.
- “Extrusion process + short tube-matching TIG welding” technique is applied to branch part and smaller diameter side. (TEE) (CAP-RC)
- Please consult us when you need C, M&Q measurements other than those shown here.

ジョイント継手 JOINT-FITTINGS

TUBE SIZE (INCH-SIZE)

製品寸法表：Dimensions

単位 (Unit) = mm

呼び径 Nominal tube size	J-ティーズ [J-TEE] Joint tee			J-レジュースー [J-RC] Joint reducer		J-キャップ [J-CAP] Joint cap		
	ジョイント部 Joint 1/4", 3/8", 1/2"			ジョイント部 Joint 1/4", 3/8", 1/2"		ジョイント部 Joint 1/4", 3/8", 1/2"		
		メス[F] Female	オス[M] Male	メス[F] Female	オス[M] Male	キャップ長さ Cap length	メス[F] Female	オス[M] Male
OD	C	M	M	H	H	E	Q	Q
1/4"	43	31.5	41.5					
3/8"	45	33.5	43.5	80	90			
1/2"	45	35	45	85	95			
5/8"	52	36.5	46.5	100	110			
3/4"	52	38	48	110	120	19.1	48	58
1"	55	42	52	115	125	25.4	55	65
1 1/4"	59	45.5	55.5			38.1	68	78
1 1/2"	68	48	58			38.1	68	78
2"	68	55	65			38.1	68	78
2 1/2"	72	61.5	72.5			38.1	68	78
3"	72	68	78			38.1	68	78
4"	72	81	91			63.5	94	104
5"	90	94	104					
6"	100	107	117					

形状

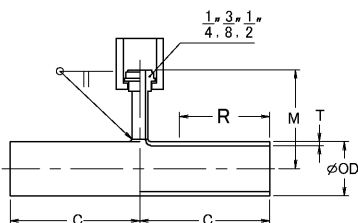

J-ティーズ [J-TEE]

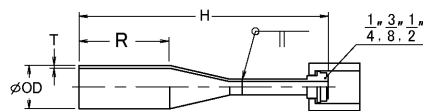

J-レジュースー [J-RC]

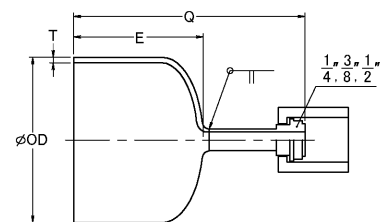

J-キャップ [J-CAP]

- 外径 (OD)、肉厚 (T)、直管部長さ (R) はページ3を参照。
- ジョイント部は“玉抜き製法+ジョイント突合せTIG溶接”とします。
- ジョイント部はVCR、UJR、MCG、JSKの1/4”、3/8”、1/2”とします。メス (F)、オス (M) も合わせてご指示下さい。
- M寸法及びQ寸法は掲記基準寸法と異なる場合がありますので、製作図面等でご確認下さい。
- Please refer to page 3 for outside diameter (OD), thickness (T) and length (R) of straight end length.
- “Extrusion process + joint-matching TIG welding” technique is applied to joint part.
- Joint part is 1/4”, 3/8”, 1/2” of VCR, UJR, MCG and JSK. Please indicate which you need, male or female.
- There are some cases where M measurements and Q measurements are different from the standard measurements shown here. Please check your requisite measurement with

フランジ接続タイプ FLANGES

TUBE SIZE (INCH-SIZE)

製品寸法表 : Dimensions

単位 (Unit) = mm

呼び径 Nominal tube size	クリーンラップ [CLLJ] Clean lap			パイプフランジ [P-F] Pipe flange	フランジ [FLANGE][BLIND] Flange, Blind				テフロン パッキング [TEFLON-P] Teflon packing 厚さ t=2 Thickness	
	長さ Length	つば径G Diameter of lap	コーナーR Corner	長さ Length	外 径 Outside dia.	厚 さ Thick- ness	ボルト数 No. of bolts	ボルト径 Dia. of bolt	外 径 Outside dia.	内 径 Inside dia.
OD	FF	G	R	FP	D	FT	N	M	OD	ID
3/4"	55	51	1.5~3	100	95	12	4	M12	58	19.5
1"	55	56	1.5~3	100	100	14	4	M12	63	26
1 1/4"	55	67	1.5~3	100	125	14	4	M16	74	32.5
1 1/2"	70	76	2~4	100	135	16	4	M16	84	38.5
2"	70	81	2~4	100	140	16	4	M16	89	51.5
2 1/2"	70	96	2~4	100	155	16	4	M16	104	64
3"	75	116	2.5~5	100	175	18	4	M16	124	77
4"	75	136	2.5~5	100	195	18	8	M16	144	102.5
5"	85	182	3~6	200	250	20	8	M20	190	128
6"	90	212	3~6	200	280	22	8	M20	220	153.5

形状

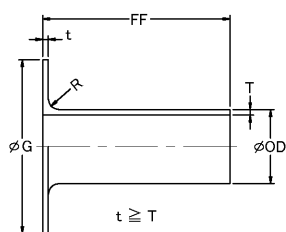

クリーンラップ[CLLJ]

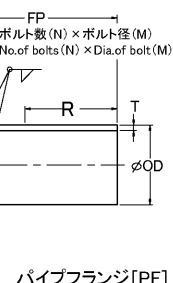
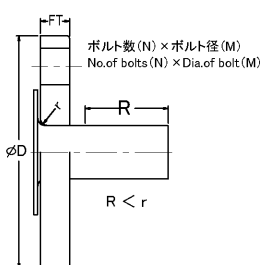

パイプフランジ[PF]

- 外径 (OD)、肉厚 (T)、直管部長さ (R) はページ3を参照。
- クリーンラップのルーズフランジの材質は SUS304を標準とします。
- パイプフランジ内面の隅肉溶接は研磨され、その表面粗さは要求仕様を確保します。(BA, EP)
- フランジは JIS B2220-10Kタイプと同等品です。パイプフランジ及び研磨仕様のフランジはRFタイプとします。
- テフロンパッキングの寸法は“JIS B2202管フランジのガスケット座寸法”を準用します。

- Please refer to page 3 for outside diameter (OD), thickness (T) and length (R) of straight end length.
- Standard material used for clean lap loose flanges is SUS304.
- The fillet welded interior of the pipe flange is polished, and its surface roughness can be finished according to your specifications. (BA, EP)
- Flanges are JIS B2220-10K type equivalent. Pipe flanges and polished flanges are RF type.
- "JIS B2202 flange gasket seat size" applies to our teflon packing measurement.

ヘッダー HEADERS

TUBE SIZE (INCH-SIZE)

製品寸法表 : Dimensions

単位 (Unit) = mm

母管 呼び径 Nominal tube size	クリーンヘッダー [KCH] 枝管 OD (最小ピッチPは、J-KCHにも適用) Clean header Branch tube (Minimum pitch P applies to J-KCH.)														母管 Mother tube	J-ヘッダー [J-KCH] Joint-header	
	最小ピッチP Minimum Pitch	1/4"	3/8"	1/2"	5/8"	3/4"	1"	1 1/4"	1 1/2"	2"	2 1/2"	3"	4"	最小管端長さ Length of minimum end		枝管高さ M Branch tube height	
OD	枝管高さM Branch tube height													EL	メス [F] Female	オス [M] Male	
1/4"	P=	45												21	31.5	41.5	
	M=	35															
3/8"	P=	45	45											21	33.5	43.5	
	M=	37	37														
1/2"	P=	45	45	45										21	35	45	
	M=	39	39	39													
5/8"	P=	55	55	55	57									27	36.5	46.5	
	M=	44	44	44	49												
3/4"	P=	55	55	55	57	59								30	38	48	
	M=	44	44	44	52	52											
1"	P=	55	55	55	57	59	62							33	42	52	
	M=	47	47	47	55	55	55										
1 1/4"	P=	55	55	55	57	59	62	65						40	45.5	55.5	
	M=	50	50	50	59	59	59	59									
1 1/2"	P=	55	55	55	57	59	62	68	73					45	48	58	
	M=	54	54	54	62	62	62	62	74								
2"	P=	60	60	60	62	64	67	70	75	83				50	55	65	
	M=	57	57	57	65	65	65	65	77	77							
2 1/2"	P=	63	63	63	65	68	70	74	78	86	94			65	61.5	72.5	
	M=	63	63	63	71	71	71	71	83	83	90						
3"	P=	67	67	67	68	71	74	78	82	90	98	104		68	68	78	
	M=	71	71	71	79	79	79	79	90	90	97	97					
4"	P=	80	80	80	85	89	92	95	100	103	110	120	130	86	81	91	
	M=	87	87	87	95	95	95	95	105	105	110	110	110				

形状

最大長さ Max.length L=6,096mm (20feet)

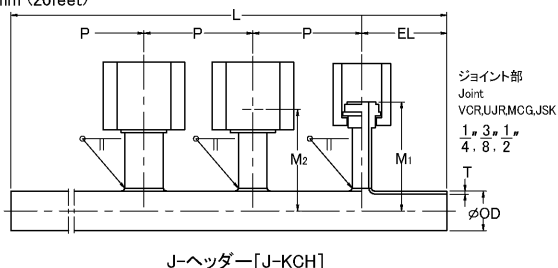
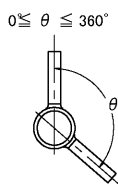
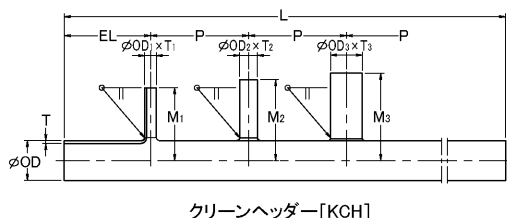

- 外径 (OD)、肉厚 (T)、直管部長さ (R) はページ3を参照。
- 長さ4,000L超、外径4"超をご要望の場合はお問い合わせ下さい。
- 枝部は“玉抜き製法+枝管突合せTIG溶接”とします。
- となり合う枝管が異なる径の場合の最小ピッチ (P) は大径側のピッチを基準とします。
- 2本の枝管がピッチ (P) を取る場合の角度 θ は任意に取ることができま

- Please refer to page 3 for outside diameter (OD), thickness (T) and length (R) of straight end length.
- When you need length over 4,000L and outside diameter over 4", please ask us whether it is available.
- "Extrusion process + branch tube-matching TIG welding" technique is applied to branch part.
- Where neighboring branch tubes have different diameters, the minimum pitch is based on the larger diameter side pitch.
- When two branch tubes take a pitch (P), pitch angle θ can be determined at your option.





二重管継手(ダブルフィット)。

DOUBLE-FIT

ダブルフィット(Double-Fit)は登録商標です。DOUBLE-FIT is a registered trade mark.

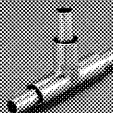
製品寸法表 : Dimensions

単位(Unit) = mm

呼び寸法 Nominal size		直管部長さ Straight end length		エルボ Elbow [D-90][D-45]			同径ティーズ Equal Tee [D-ET]		ストップ スペーサー Stop spacer [D-SS]	ハーフ チューブ Half tube [D-HT]	オーバーチューブ (TYPE1) Over tube [D-OT]
内管 Inner tube	外管 Outer tube										
		R ₁	R ₂	R	A	B	C ₁ , M ₁	C ₂ , M ₂	H	OD × T	OD × T
1/4" × 1t	1/2" × 1t 1.24t	40	29	25	94	80	82	42	9	12.7 × 1.0 1.24	15 × 1.05
	8A × S5S	40	29	26	95	80	82	42	9	13.8 × 1.2	16.5 × 1.25
3/8" × 1t	5/8" × 1t 1.24t	40	36	28	104	88	89	49	9	15.88 × 1.0 1.24	18.5 × 1.2
	10A × S5S	40	36	30	106	89	89	49	9	17.3 × 1.2	20 × 1.25
1/2" × 1t 1.24t	3/4" × 1.24t	40	36	35	111	91	92	52	9	19.05 × 1.24	22 × 1.35
	15A × S5S	40	36	38	114	92	92	52	9	21.7 × 1.65	25.4 × 1.7
3/4" × 1.24t 1.65t	20A × S5S	40	36	47.6	124	96	105	65	12	27.2 × 1.65	ページ15を参照 オーバーチューブ (タイプ2) Over tube (TYPE2) Please refer to page 15
1" × 1.24t 1.65t	25A × S5S	40	36	57.2	134	100	108	68	12	34.0 × 1.65	
1 1/2" × 1.65t	2" × 1.65t	46	46	95.3	188	132	123	77	12	50.8 × 1.65	
2" × 1.65t	2 1/2" × 1.65t	46	51	120	217	147	136	90	12	63.5 × 1.65	
10A × S5S	20A × S5S	40	36	47.6	124	96	95	55	12	27.2 × 1.65	
15A × S5S	25A × S5S	40	36	57.2	134	100	99	59	12	34.0 × 1.65	
20A × S5S	32A × S5S	40	46	76.2	163	118	114	74	12	42.7 × 1.65	
25A × S5S	40A × S5S	40	46	95.3	182	126	117	77	12	48.6 × 1.65	
32A × S5S	50A × S5S	46	46	114.3	207	140	129	83	12	60.5 × 1.65	

形状

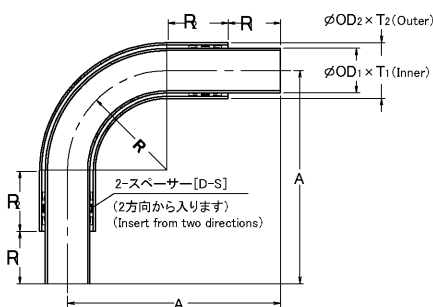

90° エルボ [D-90]

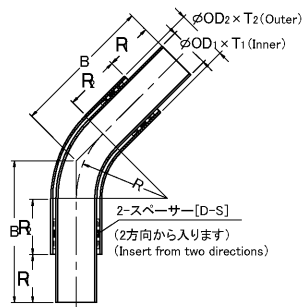

45° エルボ [D-45]

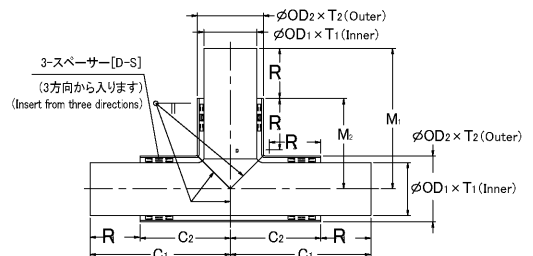

同径ティーズ [D-ET]

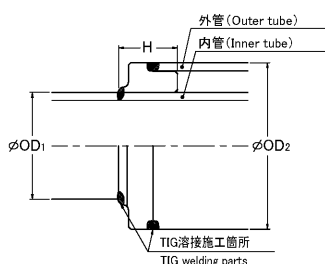

ストップスペーサー [D-SS]

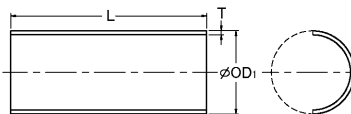

L: 標準80mm、最大1,800mm
外管と同一寸法
L: Standard 80mm, Max.1,800mm.
The same size as outer tube

ハーフチューブ [D-HT] (2個で1組)
(2 component assembly)

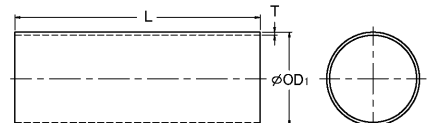

L: 標準100mm、最大4,000mm
外管の外側に入ります。
L: Standard 100mm, Max.4,000mm.
Insert in outside of outer tube

オーバーチューブ (TYPE1) [D-OT]

(D-S: Spacer)

二重管継手(ダブルフィット)レジュューサー

DOUBLE-FIT® [D-RC] [D-RE] DOUBLE CONCENTRIC/ECCENTRIC REDUCERS

製品寸法組合せ表 Reducer size combination table : Dimensions

内管 Inner tube		外管 Outer tube	
大径側 Large end	小径側 Small end	大径側 Large end	小径側 Small end
1/4"	[1/8"]	1/2"	3/8", (1/4")
		8A	1/2", 3/8", 1/4"
3/8"	[1/4"]	5/8"	1/2", 8A
		10A	1/2", 8A
1/2"	3/8", [1/4"]	3/4"	5/8", 1/2", 10A, (8A)
		15A	5/8", 1/2", 10A, (8A)
3/4"	1/2", [3/8", 1/4", 10A]	20A	15A, 10A, 8A, 3/4", 1/2", 20A
		1"	3/4", (5/8"), 1/2", 15A, (10A~8A)
1"	3/4", 1/2", [3/8", 1/4", 15A] (10A)	1 1/4"	1", (3/4", 20A), (5/8"~1/2", 15A~8A)
		25A	25A, 20A, 15A, 10A, 8A, 1", 3/4", 1/2"
1 1/2"	1", [3/4", 25A] (1/2"~1/4", 20A~10A)	2"	(1 1/4"), 1", (40A), (3/4"~1/2", 32A~8A)
2"	1 1/2", 1", (3/4"~1/4", 32A~10A)	2 1/2"	2", 1 1/4", 50A, (1"~1/2", 40A~8A)
10A	[1/2", 3/8", 1/4"]	20A	15A, [10A, 8A, 3/4", 1/2"]
15A	[10A, 3/4", 1/2", 3/8", 1/4"]	25A	20A, 15A, [10A, 8A, 1", 3/4", 1/2"]
20A	15A, [10A, 1", 3/4", 1/2", 3/8", 1/4"]	32A	25A, 20A, 15A, [1 1/4"] (10A~8A, 1"~1/2")
25A	20A, 15A, [10A, 1", 3/4", 1/2", 3/8", 1/4"]	40A	32A, 25A, 20A, 15A, (10A~8A, 1 1/4"~1/2")
32A	25A, 20A, 15A, [1 1/2"] (10A, 1"~1/4")	50A	40A, 32A, 25A, 20A, [2"] (15A~8A, 1 1/4"~1/2")

形状

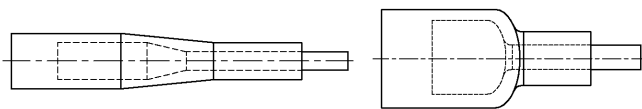

[D-RC]

- 上記製品寸法についてはお問い合わせください。
- 外径 (OD)、肉厚 (T) はページ2及び3を参照。
- 偏心タイプについてはお問い合わせ下さい。
- 上記レジュューサーの小径側で [] () の同心・偏心タイプについてはお問い合わせ下さい。
- Please contact us for the reducer sizes listed above.
- Please refer to pages 2 and 3 for outside diameter (OD) and thickness (T).
- Please contact us for eccentric type reducers.
- Please contact us for reducers of concentric or eccentric type listed in [] () of smaller diameter side category.

二重管継手(ダブルフィット)オーバーチューブ(タイプII)

DOUBLE-FIT® [D-OT] OVER TUBE (TYPE II)

製品寸法表 : Dimensions

単位 (Unit) = mm

外管呼び径 Nominal tube size	OD ₁	ID	t	L
1/2"	15.88	13.0	1.0	100
5/8"	19.05	16.2	1.24	100
3/4"	21.7	19.3	1.65	100
1"	27.2	25.7	1.65	100
1 1/4"	34.0	32.1	1.24	100
1 1/2"	42.7	38.4	1.65	112
2"	60.5	51.1	1.65	112
2 1/2"	76.2	63.8	1.65	122
8A	15.88	14.1	1.0	100
10A	19.05	17.6	1.24	100
15A	25.4	22.0	1.24	100
20A	31.8	27.5	1.65	100
25A	38.1	34.3	1.65	100
32A	48.6	43.0	1.65	112
40A	54.0, 60.5	48.9	1.65	112
50A	65.0, 76.3	60.8	2.0	112

形状

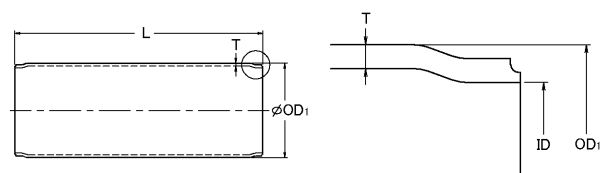

オーバーチューブ(タイプII) [D-OT]

- 既存の溶接クランプをそのまま使用できる様に管端を絞ってあるオーバーチューブです。
- Over tube's end is narrowed so that a conventional welding clamp can be used.

二重管継手(ダブルフィット)®異径ティーズ DOUBLE-FIT® [D-RT] DOUBLE REDUCING TEES

製品寸法表 : Dimensions

単位(Unit)=mm

呼び径 Nominal tube size				内管 Inner tube		外管 Outer tube	
内管 Inner tube		外管 Outer tube		C ₁	M ₁	C ₂	M ₂
母管 Nominal tube size	枝管 Branch tube size	母管 Nominal tube size	枝管 Branch tube size				
3/8"	1/4"	5/8", 10A	8A, 1/2"	87	84	47	44
1/2"	1/4"	3/4", 15A	8A, 1/2"	87	84	47	44
	3/8"		10A, 5/8"	92	92	52	52
3/4"	1/4"	1", 20A	8A, 1/2"	87	87	47	47
	3/8", 1/2"		10A, 5/8", 15A, 3/4"	95	95	55	55
1"	1/4"	1 1/4", 25A	8A, 1/2"	87	90	47	50
	3/8", 1/2", 10A, 3/4", 15A		10A, 5/8", 15A, 3/4", 20A, 1", 25A	99	99	59	59
1 1/2"	1/4"	2"	8A, 1/2"	103	97	57	57
	3/8", 1/2", 10A, 3/4", 15A, 1"		10A, 5/8", 15A, 3/4", 20A, 1", 25A, 1 1/4"	114	105	68	65
	20A, 25A		32A, 40A	123	117	77	77
2"	1/4"	2 1/2"	8A, 1/2"	107	103	61	63
	3/8", 1/2", 10A, 3/4", 15A, 1"		10A, 5/8", 15A, 3/4", 20A, 1", 25A, 1 1/4"	118	111	72	71
	20A, 25A		32A, 40A, 2", 50A	136	123	90	83
	1 1/2", 32A		32A, 40A, 2", 50A	136	129	90	83
10A	1/4"	20A	8A, 1/2"	87	87	47	47
	3/8", 1/2"		10A, 5/8", 15A, 3/4"	95	95	55	55
15A	1/4"	25A	8A, 1/2"	87	90	47	50
	3/8", 1/2", 10A, 3/4"		10A, 5/8", 15A, 3/4", 20A, 1"	99	99	59	59
20A	1/4"	32A	8A, 1/2"	97	94	57	54
	3/8", 1/2", 10A, 3/4", 15A, 1"		10A, 5/8", 15A, 3/4", 20A, 1", 25A, 1 1/4"	108	102	68	62
25A	1/4"	40A	8A, 1/2"	97	97	57	57
	3/8", 1/2", 10A, 3/4", 15A, 1"		10A, 5/8", 15A, 3/4", 20A, 1", 25A, 1 1/4"	108	105	68	65
	20A		32A	117	117	77	77
32A	1/4"	50A	8A, 1/2"	103	103	57	63
	3/8", 1/2", 10A, 3/4", 15A, 1"		10A, 5/8", 15A, 3/4", 20A, 1", 25A, 1 1/4"	114	111	68	71
	20A, 25A		32A, 40A	129	123	83	83

形状

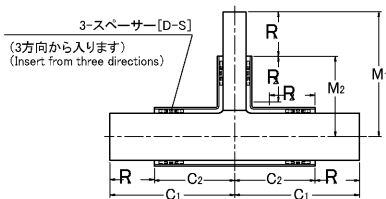

異径ティーズ[D-RT]

- 外径 (OD)、肉厚 (T)、直管部長さ (R) はページ2及び3参照。
- 枝管部は“玉抜き製法+短管突合せTIG溶接”とします。
- 掲記以外のC、M寸法、又は上記以外の組合せをご要望の場合はご相談下さい。
- Please refer to pages 2 and 3 for outside diameter (OD), thickness (T), and straight end length (R).
- Extrusion process + joint-matching TIG welding is applied to the branch pipe.
- Please contact us when you need other C, M sizes or combination than those listed above.

内管、外管の組合せ早見表 Inner tube-outer tube combination table

内管 Inner tube	外管 Outer tube
1/4" × 1t	1/2" × 1t 1.24t
	8A × 1t
3/8" × 1t	5/8" × 1t 1.24t
	10A × S5S
1/2" × 1t 1.24t	3/4" × 1.24t
	15A × S5S
3/4" × 1.24t 1.65t	20A × S5S
	1" × 1.24t 1.65t
1" × 1.24t 1.65t	25A × S5S
	1 1/4" × 1.65t
1 1/2" × 1.65t	2" × 1.65t
2" × 1.65t	2 1/2" × 1.65t
10A × S5S	20A × S5S
15A × S5S	25A × S5S
20A × S5S	32A × S5S
25A × S5S	40A × S5S
32A × S5S	50A × S5S

二重管継手(ダブルフィット)®ダブルジョイント DOUBLE-FIT® [D-JT] DOUBLE JOINT TEES

製品寸法表 : Dimensions

単位(Unit) = mm

内管 Inner tube	外管 Outer tube	内管 Inner tube			外管 Outer tube			ジョイント サイズ Joint size
		C ₁	C ₂		C ₃	M		
			メス Female	オス Male		メス Female	オス Male	
1/4"	1/2"	85	80	90	45	35	45	1/4"
	8A	85	80	90	45	35	45	
3/8"	5/8"	92	87	97	52	36.5	46.5	1/4", 3/8"
	10A	92	87	97	52	37	47	
1/2"	3/4"	92	87	97	52	38	48	1/4" ~ 1/2"
	15A	92	87	97	52	39.5	49.5	
3/4"	1"	95	90	100	55	42	52	
	20A	95	90	100	55	42.5	52.5	
1"	1 1/4"	99	94	104	59	45.5	55.5	
	25A	99	94	104	59	46.5	56.5	
10A	20A	95	90	100	55	42.5	52.5	
15A	25A	99	94	104	59	46.5	56.5	

- 外径 (OD)、肉厚 (T) はページ2及び3を参照。
- ジョイント部は“玉抜き製法+ジョイント突合せTIG溶接”とします。
- ジョイント部はVCR、UJR、MCG、JSKの1/4”、3/8”、1/2”とします。メス (F)、オス (M) も合わせてご指示下さい。
- メス (F)、オス (M) の組合せも自由に選択出来ます。ご指示ください。
- M寸法は掲記基準寸法と異なる場合もありますので製作図面等でご確認下さい。
- Please refer to pages 2 and 3 for outside diameter (OD), thickness (T).
- Extrusion process + joint-matching TIG welding is applied to the joint part.
- The joint part is 1/4", 3/8", 1/2" of VCR, UJR, MCG and JSK. Please indicate which you need, male or female.
- Combination of male and female is at your choice, please instruct us.
- In some cases M measurements may be different from the standard measurements shown here. Please check your requisite M measurements with drawings and working plans.

形状

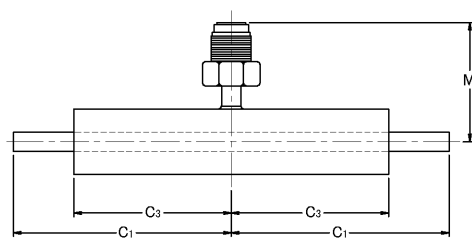

[D-JT-M]

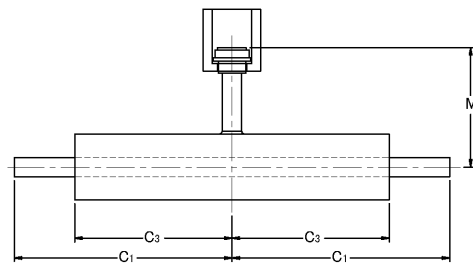

[D-JT-F]

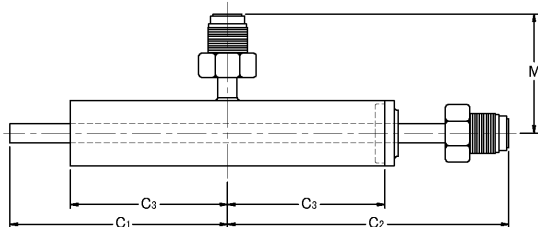

[D-JT-MM]

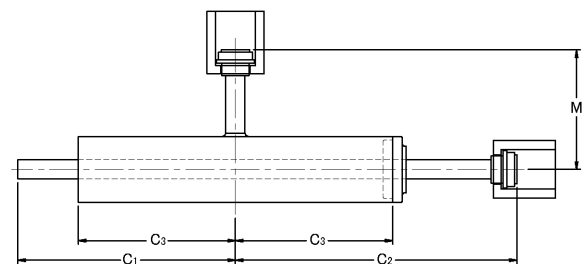

[D-JT-FF]

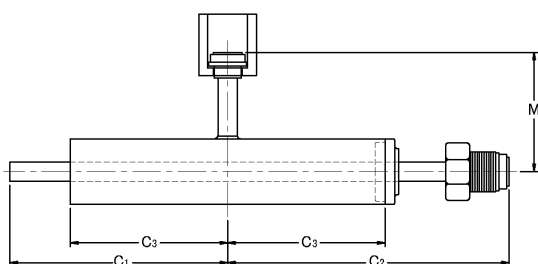

[D-JT-FM]

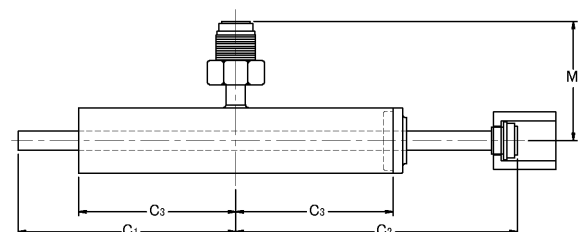

[D-JT-MF]

二重管継手(ダブルフィット)®ストップスペーサー+グランド DOUBLE-FIT® STOP SPACER + GRAND

製品寸法表 : Dimensions

呼び径 Nominal tube size	A		B
	メス Female	オス Male	
1/4"	73	80	9
3/8"	73	80	9
1/2"	73	80	9

形状

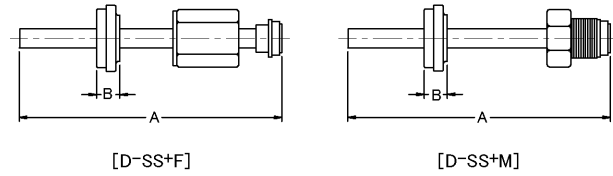

- ストップスペーサーは、固定されておりません。
- The stop spacer is not fixed.

オーバーチューブ使用方法 HOW TO USE AN OVER TUBE

接合手順 JOINT PROCESS

Step 1: オーバーチューブを二重管の外管に差し込み、内管を自動溶接します。
Insert an over tube into the outer tube of a double tube and weld the inner tube automatically.

Step 2: オーバーチューブの両端と外管を隅肉自動溶接をします。
Apply automatic fillet welding to both ends of the over tube and the outer tube.

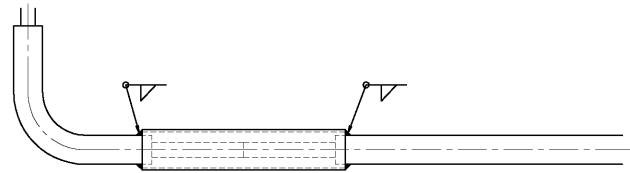
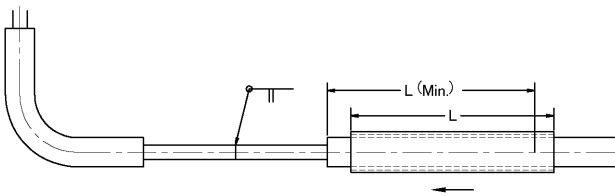

注) 片側にオーバーチューブを差し込める直管部 L (Min.) を有すること。もしこの直管部が無い場合は下記ハーフチューブの使用をご検討ください。

N.B. The right side of the tube must have a straight length L (Min.) as shown above, to allow an over tube to enter. In case the tube has no straight length L, please study if it is replaceable with

ハーフチューブ使用方法 HOW TO USE A HALF TUBE

接合手順 JOINT PROCESS

Step 1: 内管を自動溶接します。
Weld the inner tube automatically.

Step 2: 半割りの合わせ目を手動溶接し、両サイドを自動溶接します。
Weld manually the joint part of the half-cuts, and weld automatically both sides.

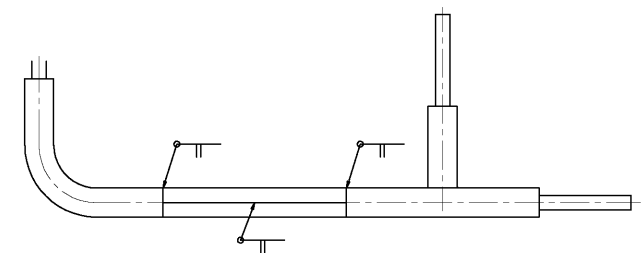
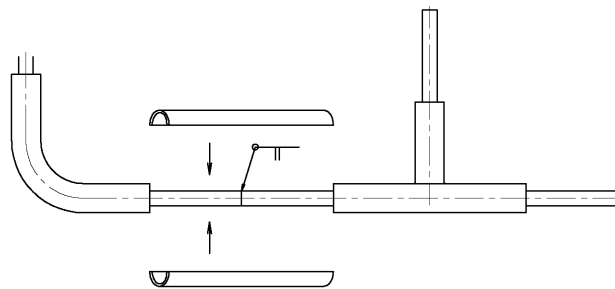

ストップスペーサー使用方法 HOW TO USE A STOP SPACER

接合手順 JOINT PROCESS

Step 1: ストップスペーサーを内管に差し込みます。
Insert a stop spacer into an inner tube.

Step 2: ストップスペーサーと内管、外管を自動溶接します。
Weld automatically the spacer, inner tube, and outer tube.

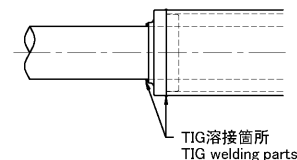
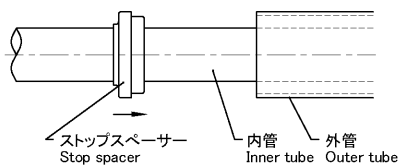

手動溶接継手

MANUAL-WELDING FITTINGS

製品寸法表 : Dimensions

単位 (Unit) = mm

呼び径 Nominal pipe size	ロングエルボ Long elbow [90LR][45LR]		ショートエルボ Short elbow [90SR][45SR]		ラップジョイント Lap joint JPF10K [LJ10K]			パイプフランジ Pipe flange [PF10K] [PF 5K]	JIS10Kフランジ JIS 10K flange [JIS 10KFL]			
	OD	A	B	A	B	FF	G	R	FP	D	FT	N
125A	190.5	78.9	127.0	52.6	50	182	5	200	250	20	8	M20
150A	228.6	94.7	152.4	63.1	50	212	5	200	280	22	8	M20
200A	304.8	126.2	203.2	84.2	65	262	5	200	330	22	12	M20
250A	381.0	157.8	254.0	105.2	65	324	5	200	400	24	12	M22
300A	457.2	189.4	304.8	126.2	65	368	5	200	445	24	16	M22
350A	533.4	220.9	355.6						490	26	16	M22
400A	609.6	252.5	406.4						560	28	16	M24
450A	685.8	284.1	457.2						620	30	20	M24

呼び径 Nominal pipe size	同径ティーズ Equal tee [E-TEE]	キャップ Cap [CAP]	枝管、小径側呼び径 Nominal sizes of branch pipe and small end	異径ティーズ Reducing tee [R-TEE]		キャップ レジュースー Cap reducer [CAP-RC]	同心、偏心レジュースー Concentric,Eccentric reducer [RC][RE]
				C	M		
OD (OD _i)	C=M	E	OD _z	C	M	Q	H
125A	123.8	76.2					127.0
150A	142.9	88.9	125A	142.9	136.5	(170)	139.7
200A	177.8	101.6	125A	177.8	161.9	(180)	152.4
			150A		168.3		
250A	215.9	127.0	125A	215.9	190.5	210	177.8
			150A		193.7		
			200A		203.2		
300A	254.0	152.4	125A	254.0	215.9	240	203.2
			150A		219.1		
			200A		228.6		
			250A		241.3		
350A	279.4	165.1	150A	279.4	238.1	250	330.2
			200A		247.7		
			250A		257.2		
			300A		269.9		
400A	304.8	177.8	150A	304.8	263.5	250	355.6
			200A		273.1		
			250A		282.6		
			300A		295.3		
			350A		304.8		
450A	342.9	203.2	150A	342.9		250	381.0
			200A		298.5		
			250A		308.0		
			300A		320.7		
			350A		330.2		
400A	330.2						

形状

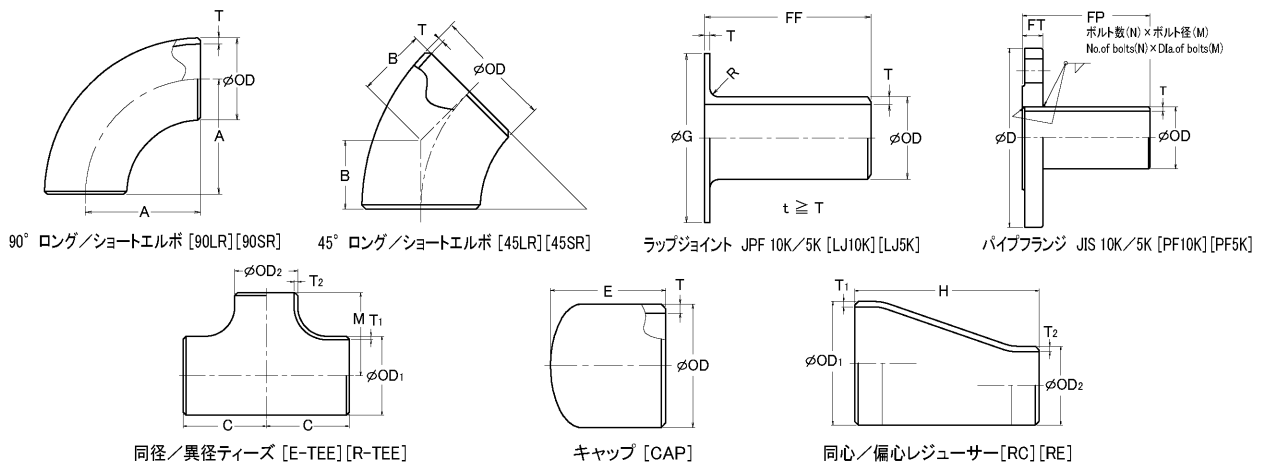

大径側手動溶接一枝管／小径側自動溶接(直管部付)継手

MANUAL WELDING OF LARGE DIAMETER SIDE - AUTOMATIC WELDING OF BRANCH PIPE/SMALL DIAMETER SIDES (WITH STRAIGHT LENGTH END) FITTINGS

製品寸法表 : Dimensions

単位 (Unit) = mm

呼び径 Nominal pipe size	枝管、小径側呼び径 Nominal sizes of branch pipe and small end	異径ティーズ Reducing tee [R-TEE]	キャップ レジュースー Cap reducer [CAP-RC]	同心、偏心 レジュースー Concentric, Eccentric reducer [RC][RE]
OD (OD ₁)	OD ₂	C M	Q	H
125A	100A, 80A, 65A, 50A	ページ5を参照 母管側ベベルエンド Please refer to page 5. Bevel end at mother pipe side	ページ5を参照 大径側ベベルエンド Please refer to page 5. Bevel end at large dia. side	190
150A	125A, 100A, 80A [65A]			205
200A	150A, 125A, 100A			220
250A	8A, 1/2", 3/8", 1/4"	110 180	170	250 270
	25A, 20A, 15A, 10A, 1", 3/4"	130 190	180	
	50A, 40A, 32A	150 200	190	
	100A, 80A, 65A	170 210	200	
	150A, 125A	190 220	210	
300A	8A, 1/2", 3/8", 1/4"	120 200	200	280 300
	25A, 20A, 15A, 10A, 1", 3/4"	140 210	210	
	50A, 40A, 32A	160 220	220	
	100A, 80A, 65A	180 230	230	
	150A, 125A	200 240	240	
350A	8A, 1/2", 3/8", 1/4"	130 220	210	
	25A, 20A, 15A, 10A, 1", 3/4"	150 230	220	
	50A, 40A, 32A	170 240	230	
	100A, 80A, 65A	190 250	240	
	150A, 125A	210 260	250	
400A	8A, 1/2", 3/8", 1/4"	130 250	220	
	25A, 20A, 15A, 10A, 1", 3/4"	150 260	230	
	50A, 40A, 32A	170 270	240	
	100A, 80A, 65A	200 280	250	
	150A, 125A	220 290	260	
450A	8A, 1/2", 3/8", 1/4"	130 280	250	
	25A, 20A, 15A, 10A, 1", 3/4"	150 290	260	
	50A, 40A, 32A	180 300	270	
	100A, 80A, 65A	200 310	280	
	150A, 125A	230 320	290	
200A	250 340			

形状

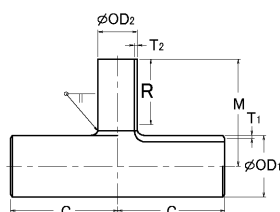

異径ティーズ [R-TEE]

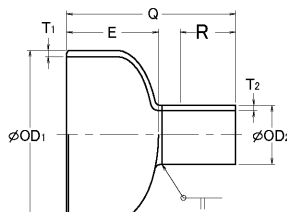

キャップレジュースー [CAP-RC]

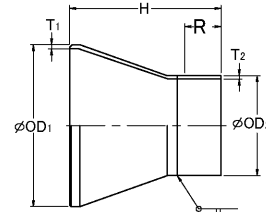

同心／偏心レジュースー [RC][RE]

- 外径 (OD)、肉厚 (T)、直管部長さ (R) はページ2及び3を参照。
- 100A 以下及び 350A～500A の手動溶接タイプも製作できます。お問い合わせください。
- 手動溶接タイプのエルボ、レジュースー、キャップ、ティーズは JIS B 2312、2313 の規格品です。ラップジョイントは JPF SP001 の規格品です。フランジは JIS B2220 の規格品です。寸法許容差はそれぞれの規格を適用します。
- テフロンパッキンはページ7を参照して下さい。但し250AはOD=333、ID=270、300AはOD=378、ID=321となります。(JIS 10K)

- Please refer to pages 2 and 3 for outside diameter (OD), thickness (T) and length (R) of straight end length.
- Manual-welding fittings below 100A and from 350A to 500A are available. Please contact us.
- Manual-welding elbows, reducers, caps and tees are JIS B2312, 2313 specification products, and lap joints are JPF SP001 specification products, and flanges are JIS B2220 specification products. Their dimensional tolerance is determined by the dimensional tolerance of respectively applicable standard.
- Please refer to page 7 for teflon packing. The size 250A has OD=333 and ID=270, and 300A has OD=378 and ID=321. (JIS10K)